

Electromagnetic Transducers

Say What?

Say What?

- Heard of a Dipole?

Say What?

- Heard of a Dipole?
- Heard of a Yagi?

Say What?

- Heard of a Dipole?
- Heard of a Yagi?
- Heard of a Quad?

Guessed Yet?

Right! It's an **Antenna**.

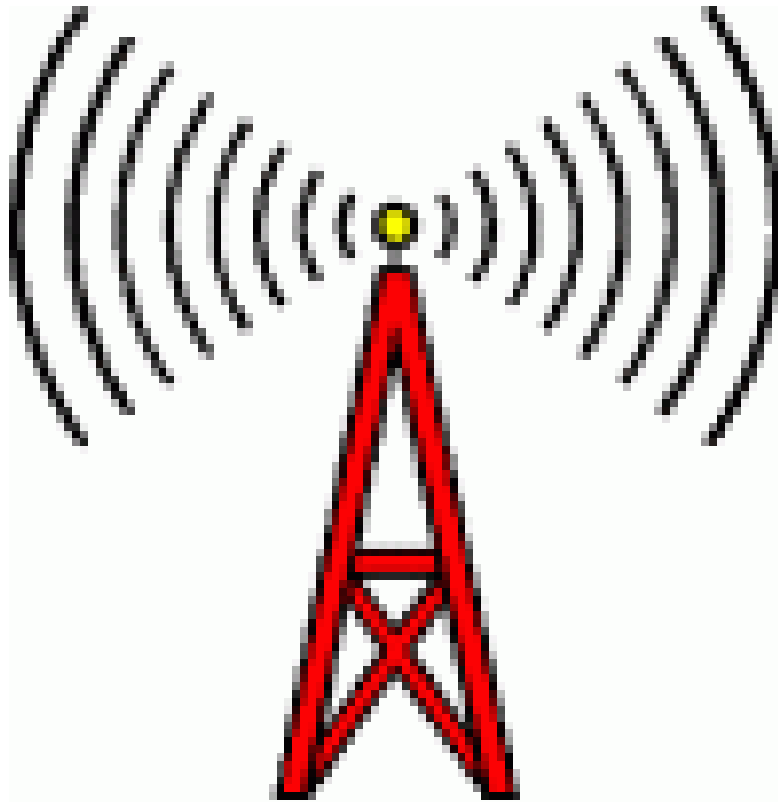

Antennas come in All Shapes and Sizes

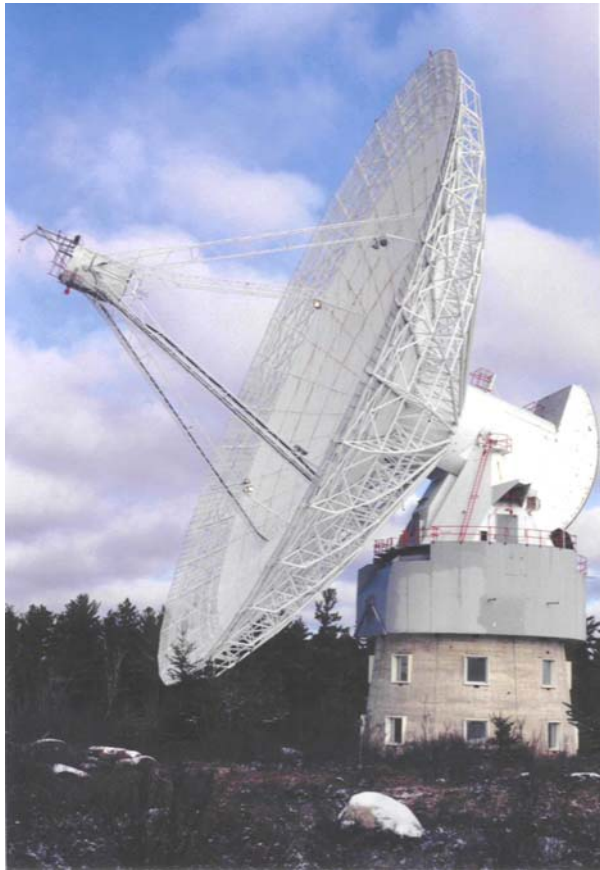

Some are **BIG**

Algonquin Radio Observatory
(46m diameter)

Antennas come in All Shapes and Sizes



Some are
VERY BIG

Arecibo, PR
1000' dia.

Antennas come in All Shapes and Sizes

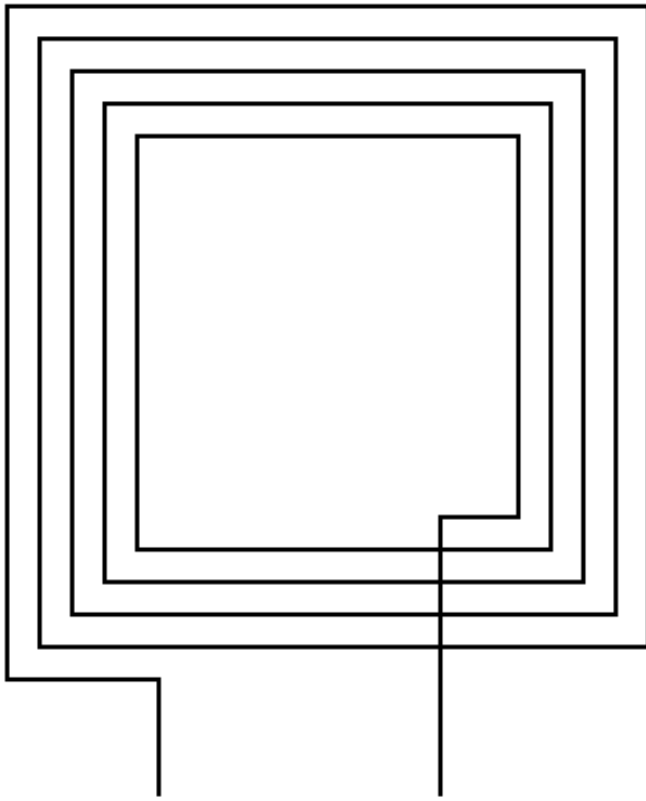

Loops for AM
Receivers

Antennas come in All Shapes and Sizes

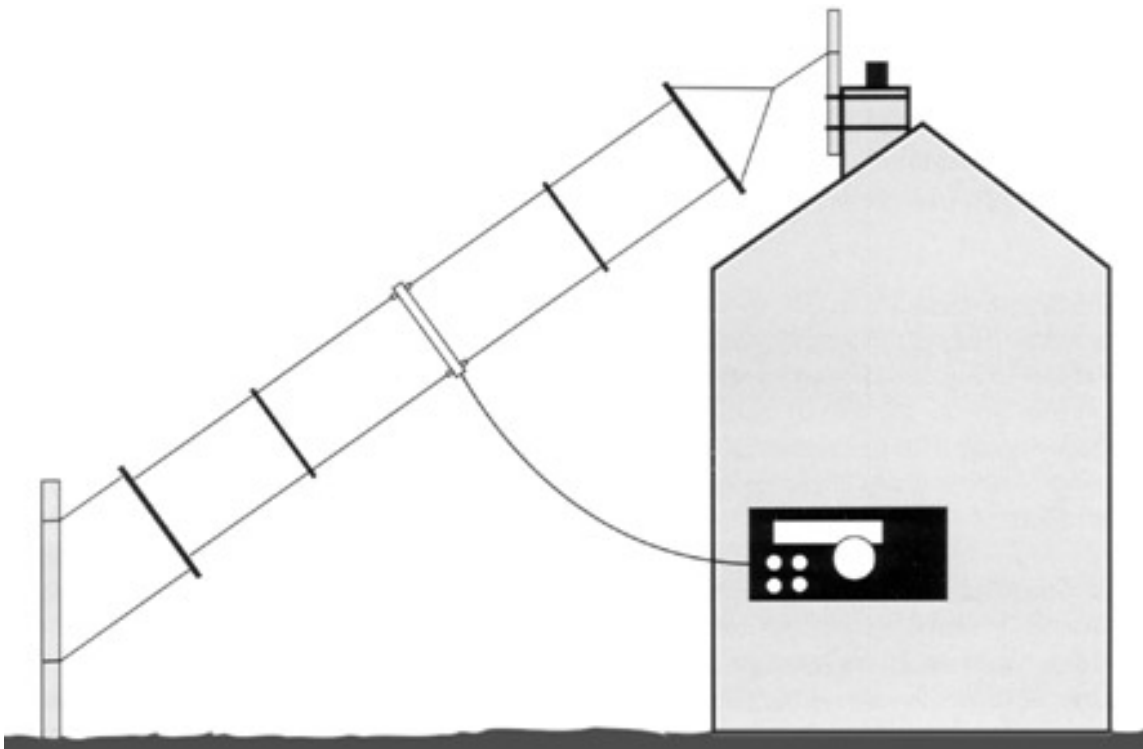

Folded
Dipole

Antennas come in All Shapes and Sizes

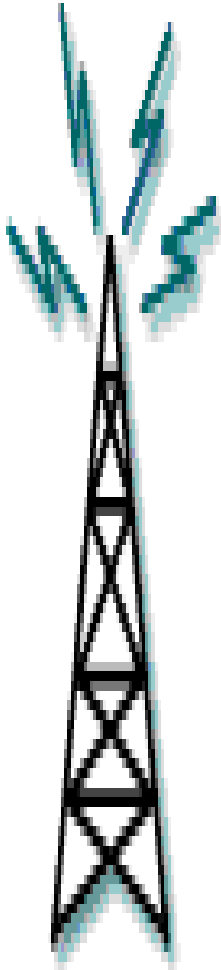

Simple Verticals

Antennas come in All Shapes and Sizes



Yagi-Uda

Reflector plus
Driver plus
Director(s)

Antennas come in All Shapes and Sizes



Log Periodic Yagi
(broadband)

Antennas come in All Shapes and Sizes



Bicycle ATV
(900MHz)

- Can you find
the antenna?

Antennas come in All Shapes and Sizes

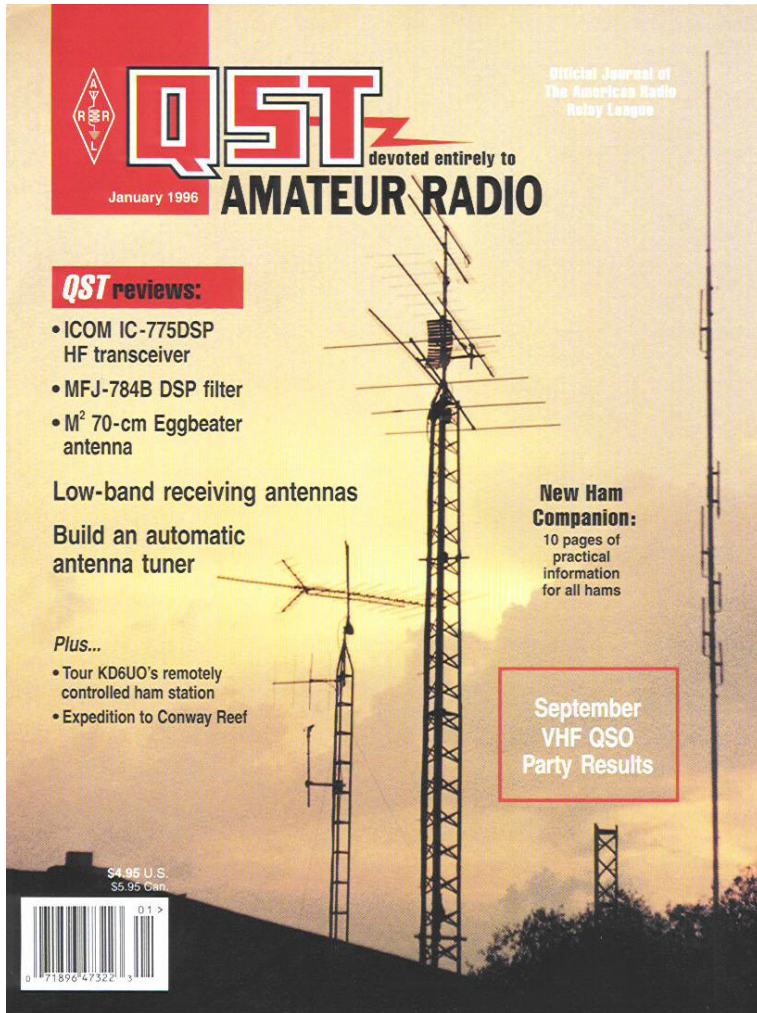

Some of my
Antennas

Antennas come in All Shapes and Sizes

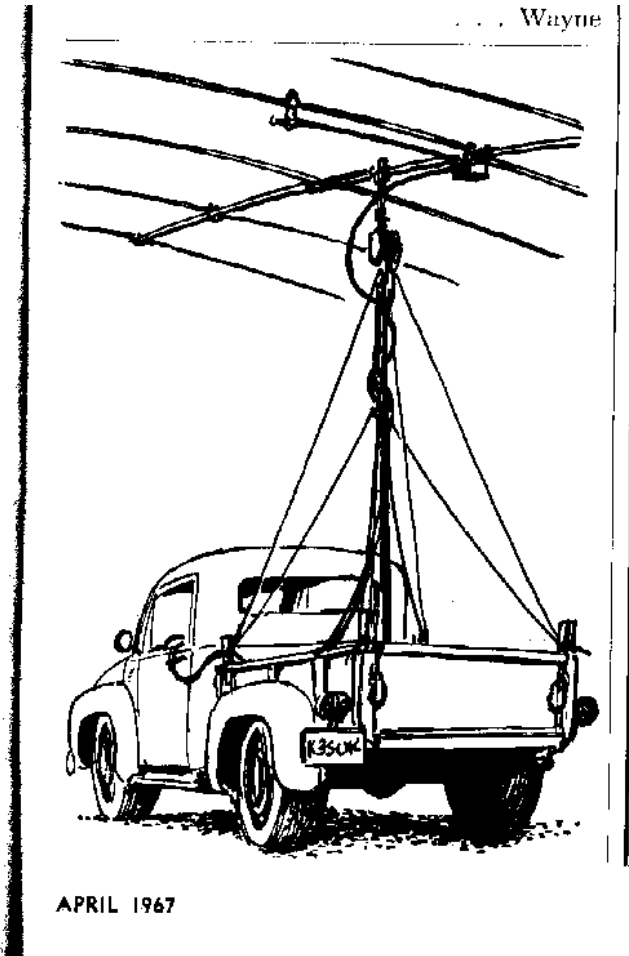

Mobile Yagis?

It's done for VHF
and UHF Contests

Antennas come in All Shapes and Sizes

Bill ... VE3CRU Rovermobile



Antennas come in All Shapes and Sizes



Stacked Mobile Yagis

432MHz

222MHz

144MHz

50MHz

Antennas come in All Shapes and Sizes



Yagi
Arrays
(K8GP)

Microwave Parabolic Antenna



Would you
believe 30dB of
gain with only
19" of diameter?

20dB over S9 at
138km with 100mW

Just about anything could make an antenna

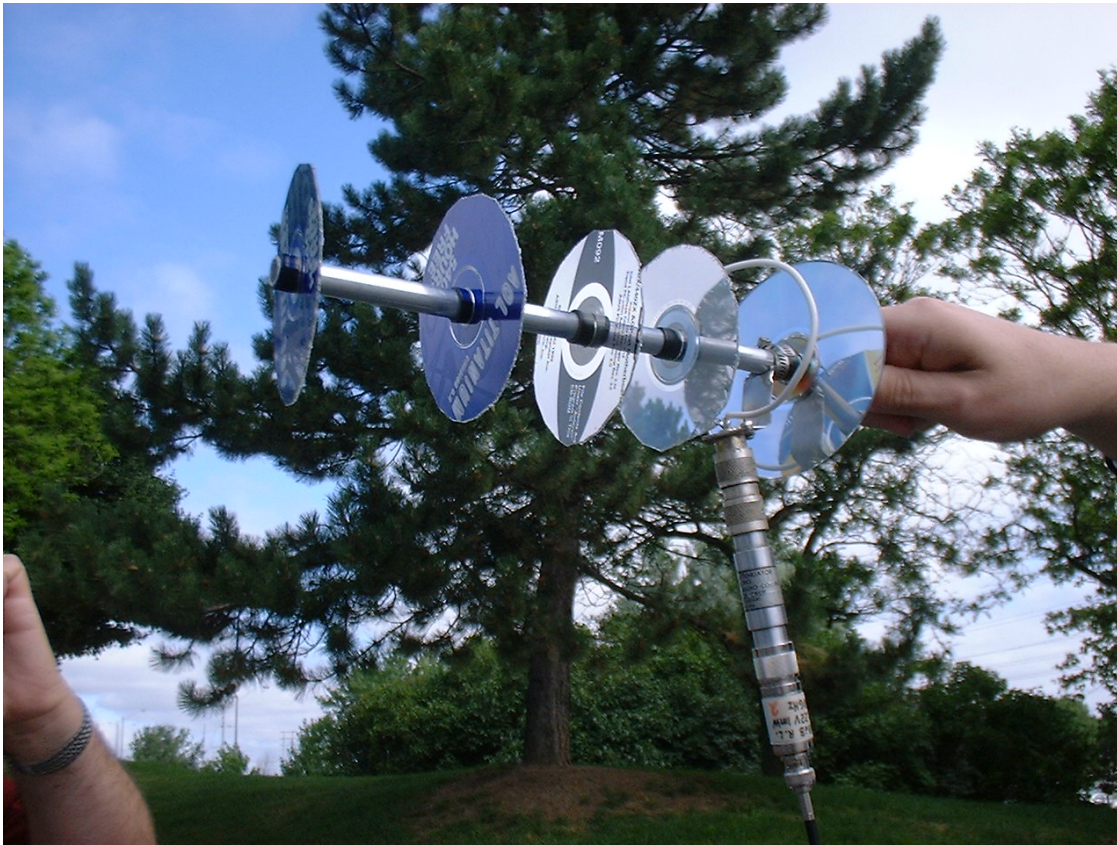

9dB Gain
at 903.1MHz!

I believe in
recycling.

Antenna Gain

- Referenced to a **half-wave dipole** for frequencies $< 1000\text{MHz}$ (1GHz)
- Referenced to an **isotropic** (point) source for frequencies $> 1\text{GHz}$

Reference Gain Antenna (7.7dBi)

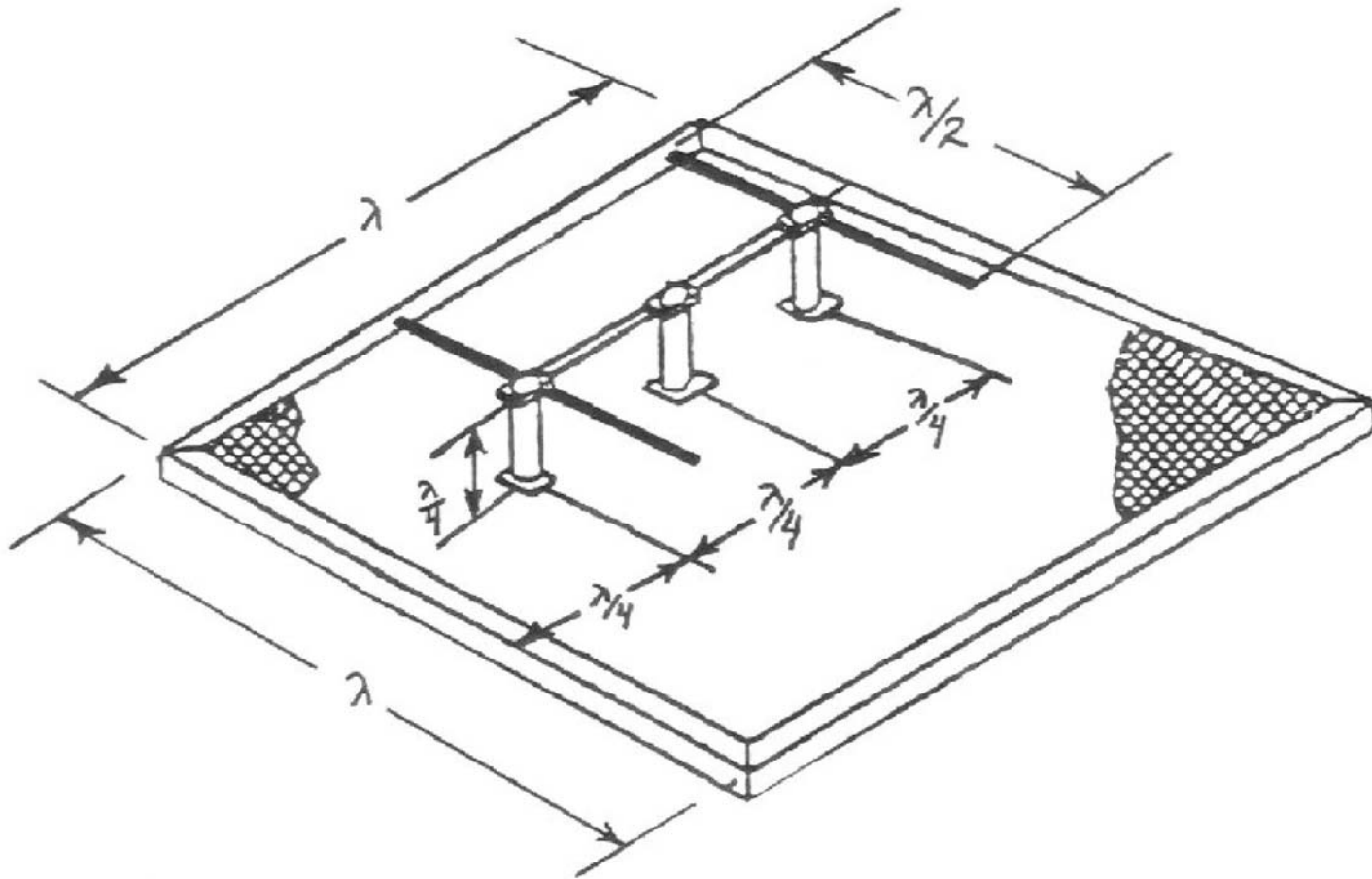

Antenna Front-to-Back Ratio

- A ratio of signal off the back of the antenna referenced to the signal off the front of the antenna
- Usually measured in dBs



DON'T LAUGH, YOU
SHOULD SEE THE
FRONT TO BACK
RATIO!



Antenna Front-to-Back Ratio

- A Dipole has a 0dB f/b ratio.
- A Vertical omni has 0dB f/b.
- A Yagi will have a f/b ratio.
- You get gain in the forward direction when you have f/b ratio.

Heard of Gouch's Theorm?

Gouch's Theorm

- RF

Gotta

Go

Somewhere!

Antenna Gain

- With Yagi Antennas, you get higher gain with more elements.
- Higher gain means more directivity and a narrower beam width.

Antenna Gain

- Stacking Yagis vertically will narrow up the vertical radiation pattern but not the horizontal pattern.
- Stacking two antennas gives 2.5 to 2.8dB of gain (3dB theoretical).

Antenna Gain

- Yagi gain is determined by both the E (electric field) and H (magnetic field) plane beamwidths.
- The narrower the beamwidths, the higher the antenna gain.

Dipole Antennas

- Half-Wave Dipole
- 0dBd Gain

70cm Dipole

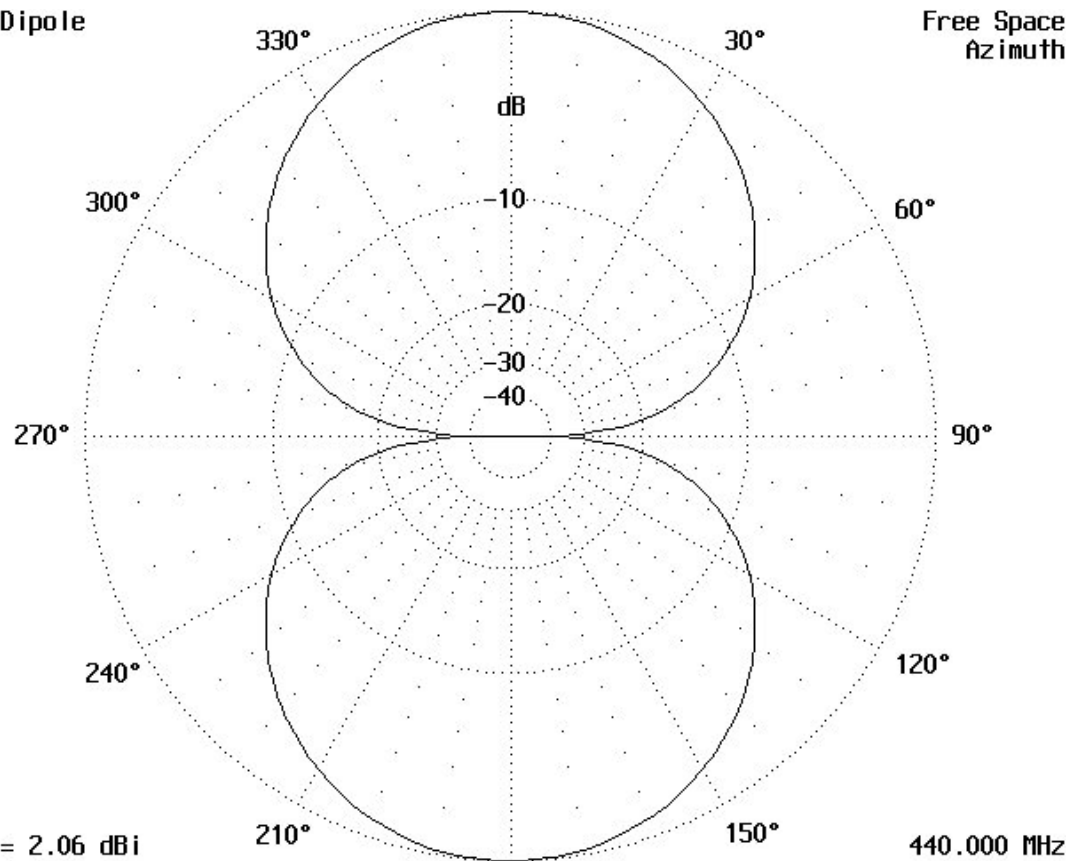

Dipole Antennas

- Full -Wave Dipole
- 0.89dBd Gain

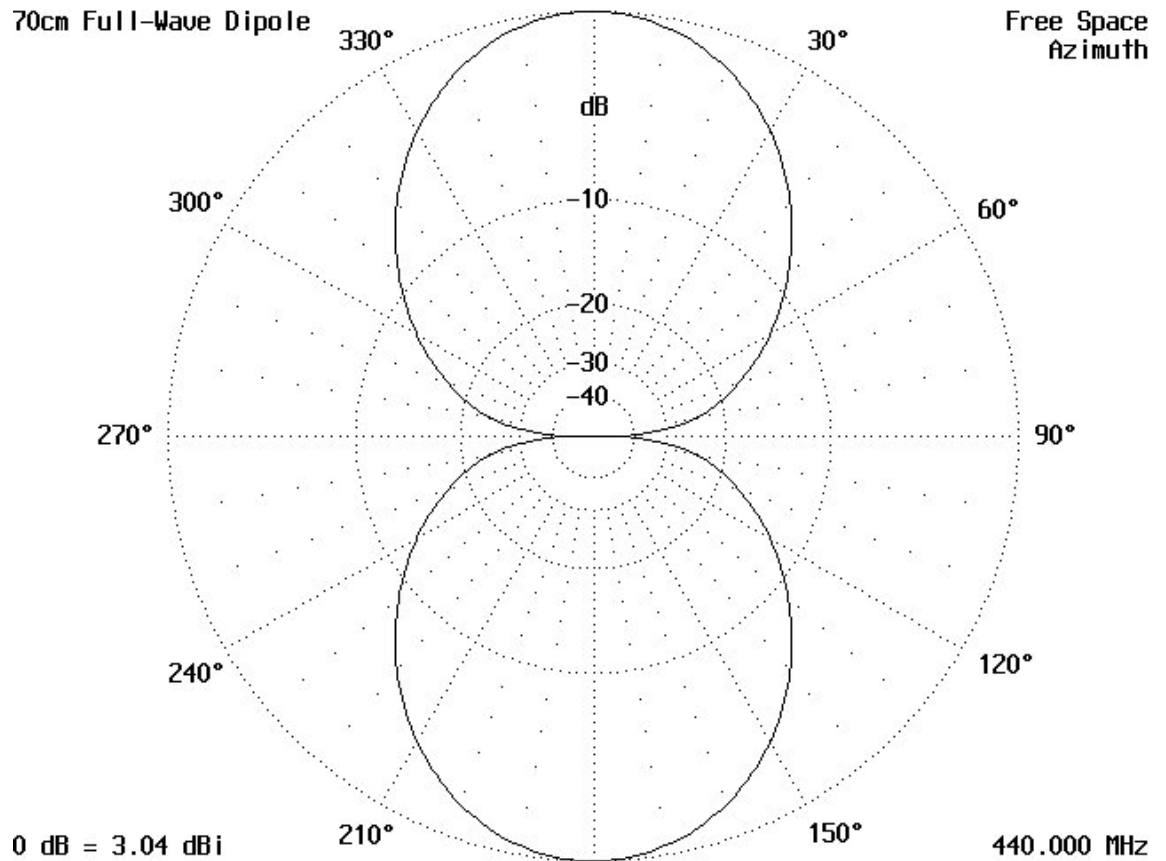

Dipole Antennas

- 1.25 -Wave Dipole (2 x 5/8 waves)
- 2.69dBd Gain

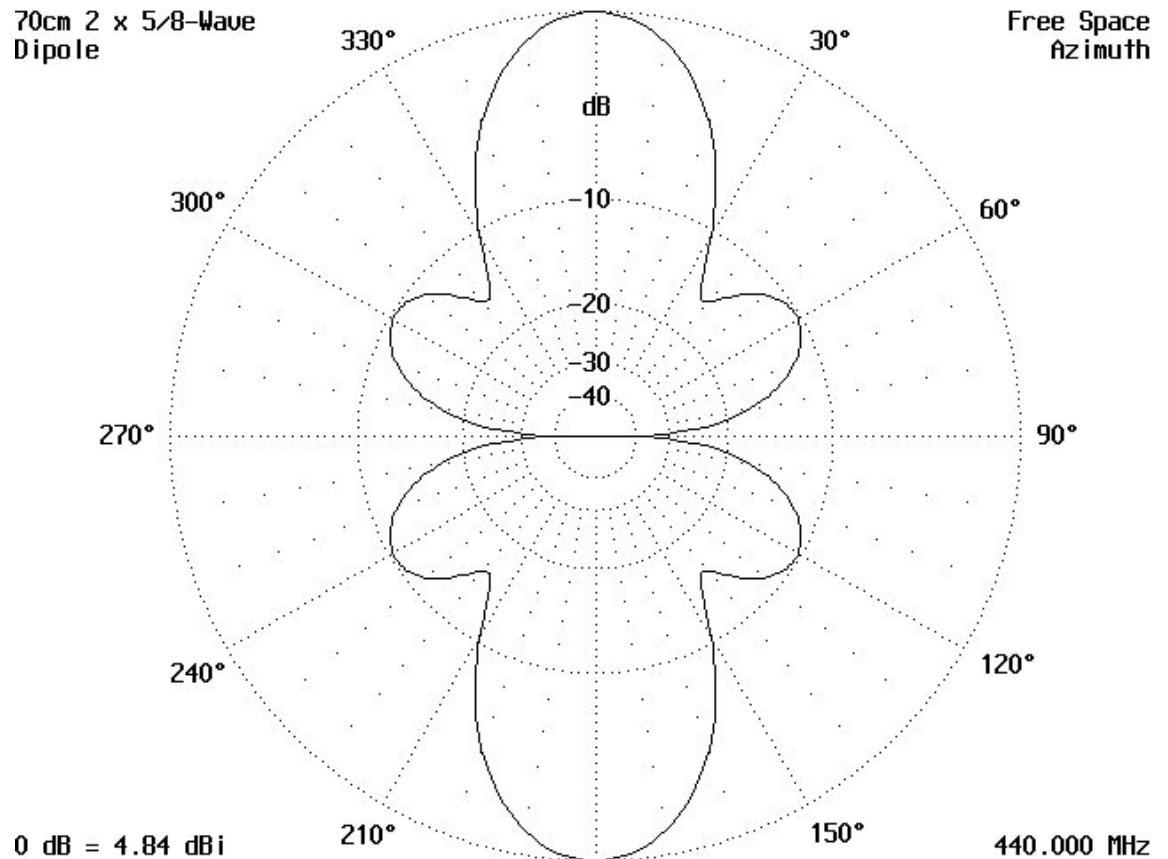

Dipole Antennas

- 1.5 -Wave Dipole
- 1.15dBd Gain

70cm 1.5-Wave Dipole

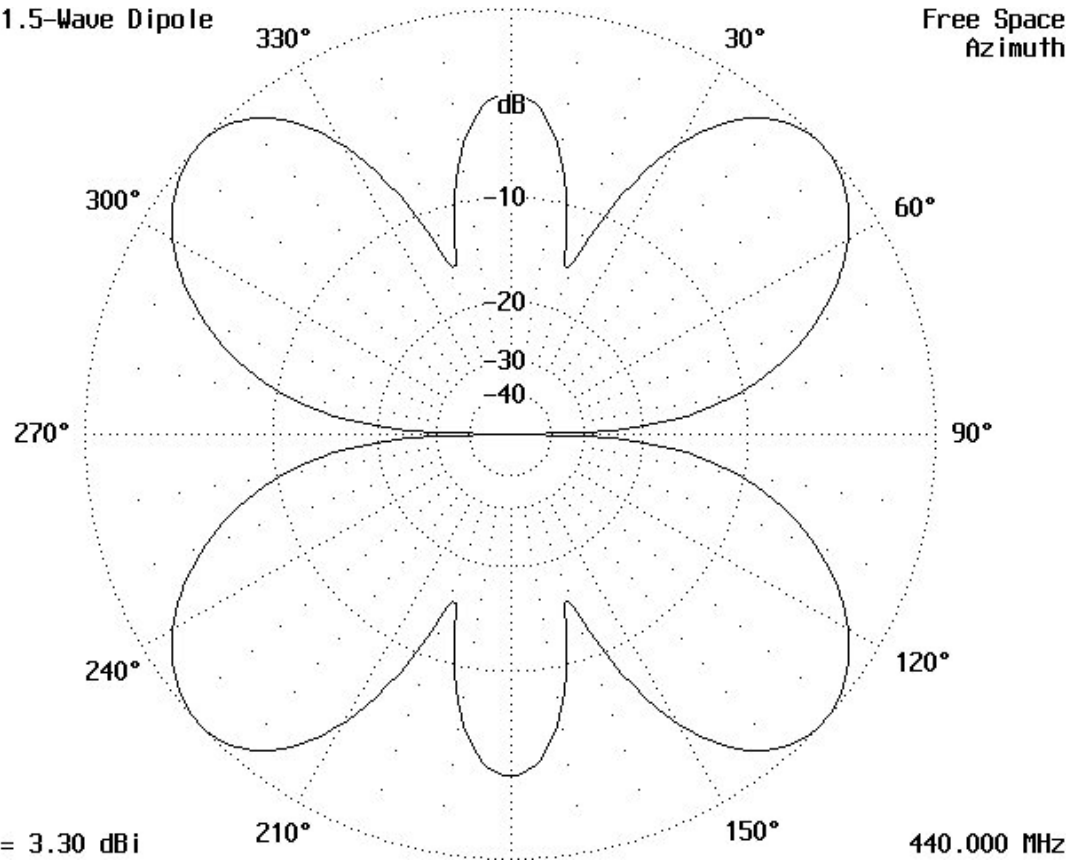

Yagi Antennas

- 4-Elements 6.3dBd Gain

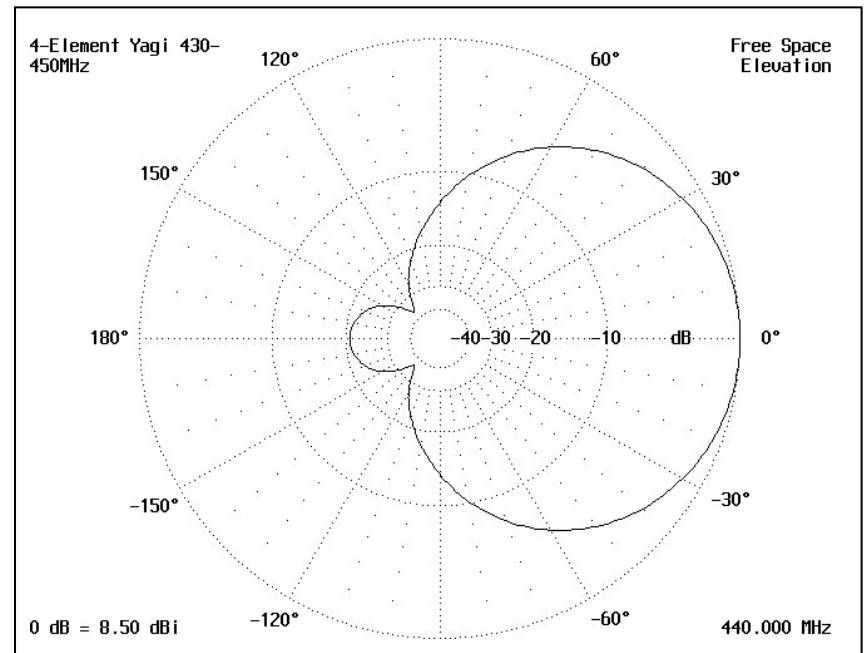
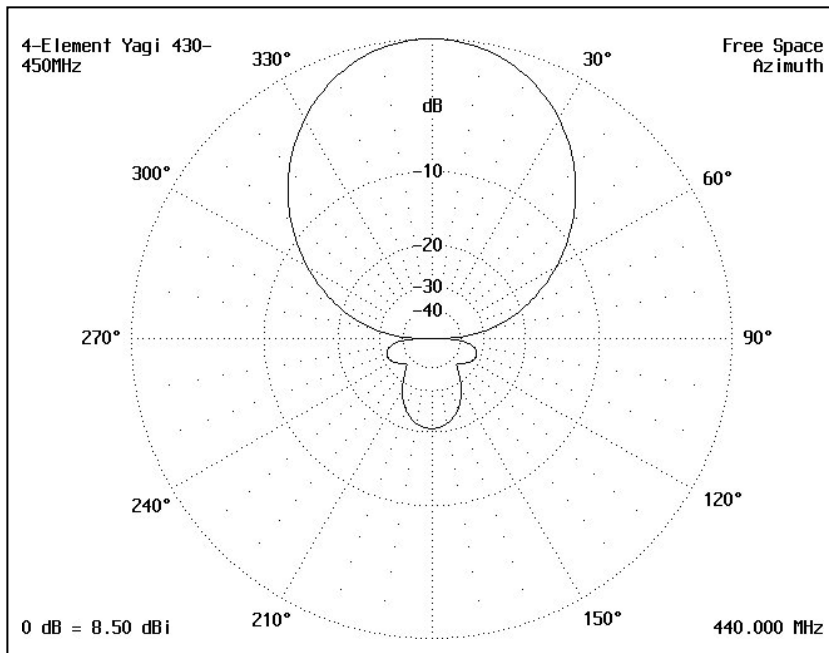

Yagi Antennas

- 7-Elements 9.8dBd Gain

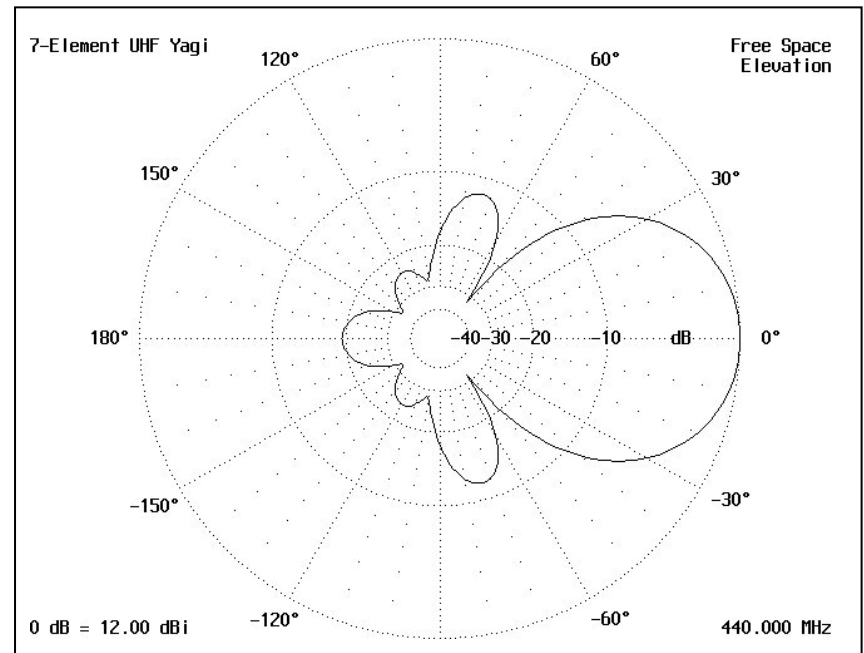
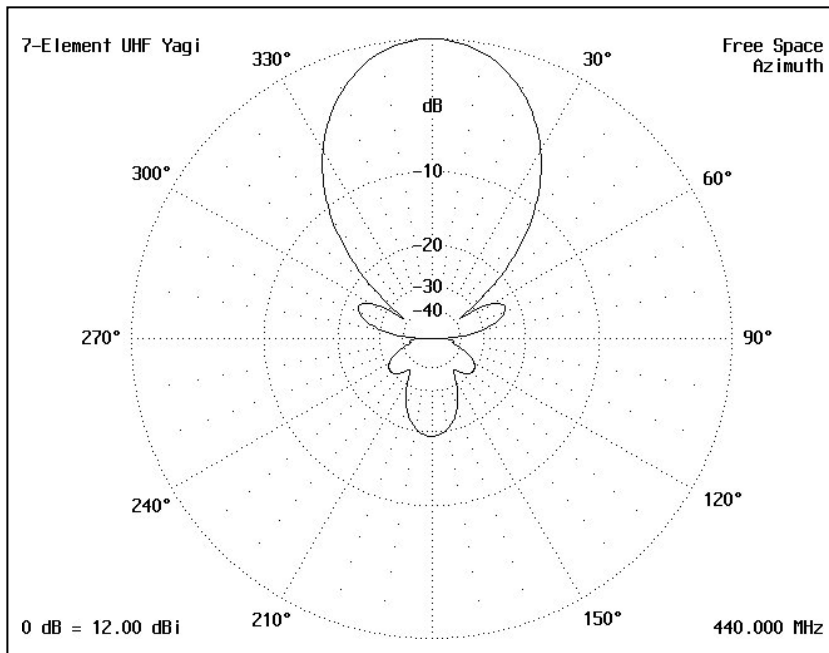

Yagi Antennas

- 16-Elements 14.3dBd Gain

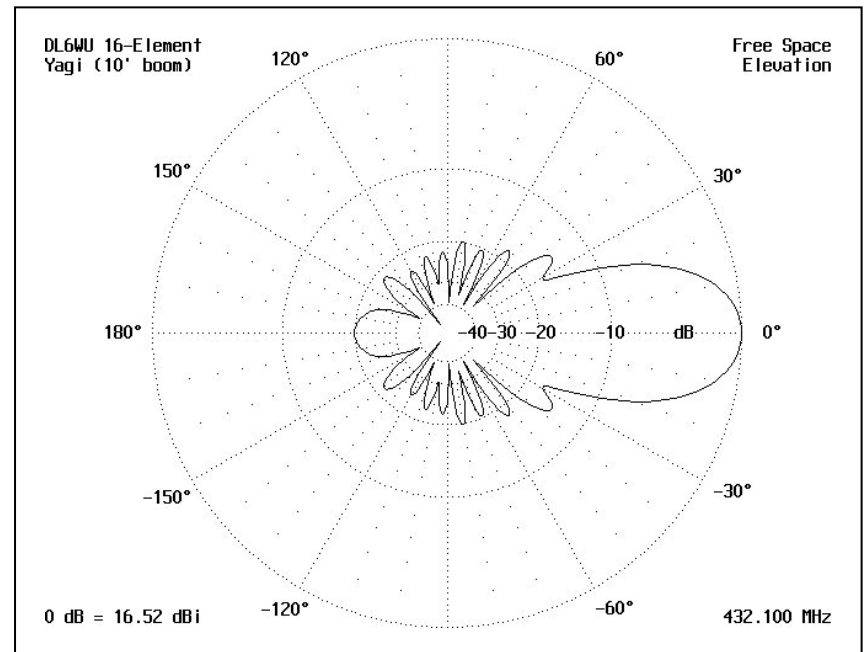
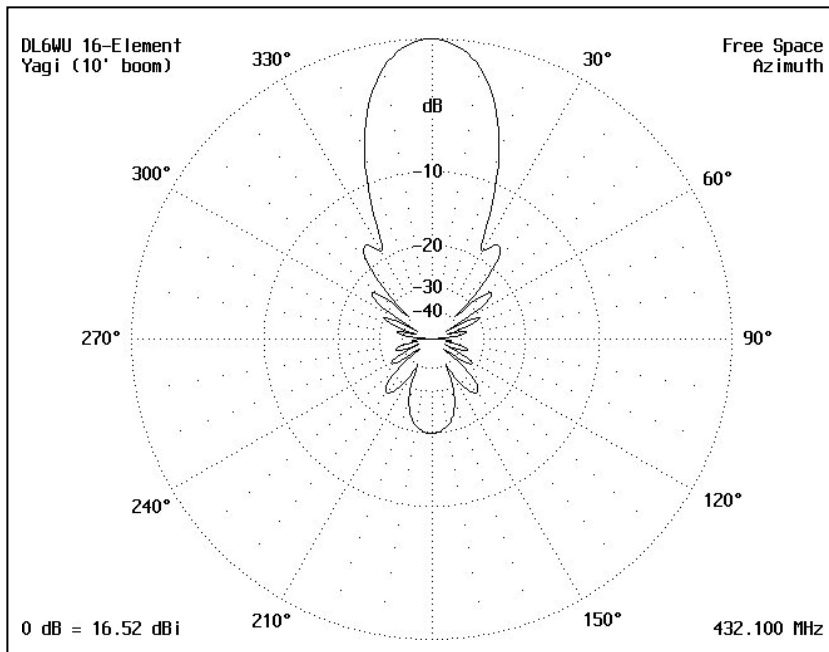

Yagi Antennas

- 21-Elements 15.8dBd Gain

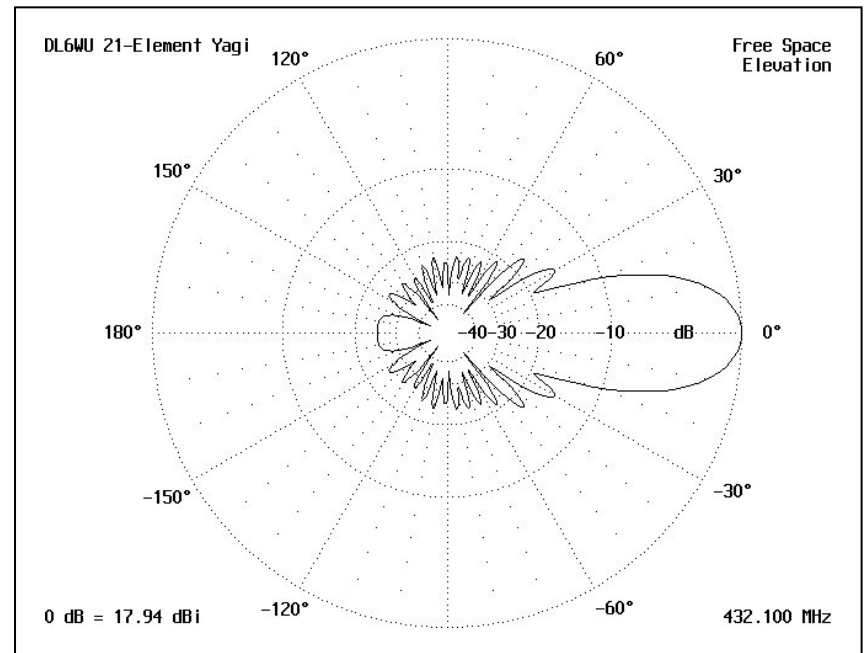
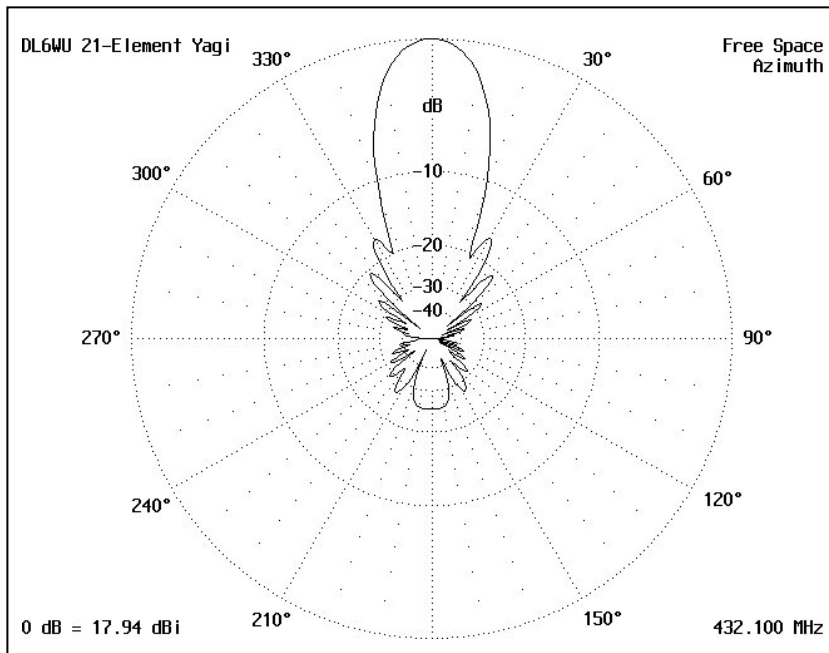

Antennas

- **Can you ever have enough antenna gain?**
- **Probably Not!**
- **Receive pre-amps help *only* the receive signal.**
- **RF amplifiers help *only* the transmit signal.**

Antennas

**Antennas help
both
on Transmit and Receive**

Antennas

**Have you listened to your
Antenna lately?**

Stay Tuned!

Antenna Test Set-Up

